



Industry 4.0  
solutions by WAMECH

# AGV X1

Automated Guided Vehicle



# AGV

# X1

- Forward and reverse drive
- Differential drive enables turning on the spot
- Wear-free charging during operation due to inductive charging system
- Scalable battery capacity with LiFePO4 batteries to adapt to process requirements
- 7" touch user interface for easy interaction
- Agent-based system that enables communication between the AGVs and their environment
- Electric lifting pin for lifting payloads up to 1500 kg
- Driving speeds from 0.02 m/s up to 1.6 m/s
- Navigation: track guided - magnetic or virtual track
- Hybrid localization: grid-sensor, contour detection, camera, RFID, odometry and magnetic track
- Safety laser scanner in each direction of travel

## Technical information

### ELECTRIC DATA

Operating voltage AGV [V]	<b>24 DC</b>
Charging time with inductive charger (for 1/2/3 batteries) (min)	<b>30   40   60*</b>
Capacity (for 1/2/3 batteries) (Ah)	<b>21   42   63</b>

### OPERATIONAL DATA

Temperature range (°C)	<b>+5 to +35</b>
Positioning accuracy (mm)	<b>+/- 5*</b>
Min. turning radius (m)	<b>1.0</b>
Max. speed with/without payload (m/s)	<b>1.0   1.6*</b>
Continuous driving without payload (for 1/2/3 batteries) (h)	<b>4   8   12*</b>

### MECHANICAL DATA

Casing material	<b>Steel/technopolymers</b>
Dimensions L   W   H (mm)	<b>840   820   340**</b>
Weight AGV (kg)	<b>215</b>
Max. topload AGV (kg)	<b>1500*</b>

\*environment-dependent  
\*\*without optional accessories





X1 Turn Table version

# Dimensions

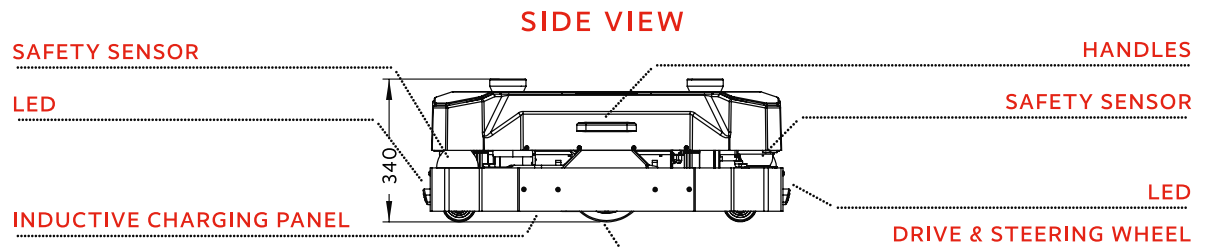
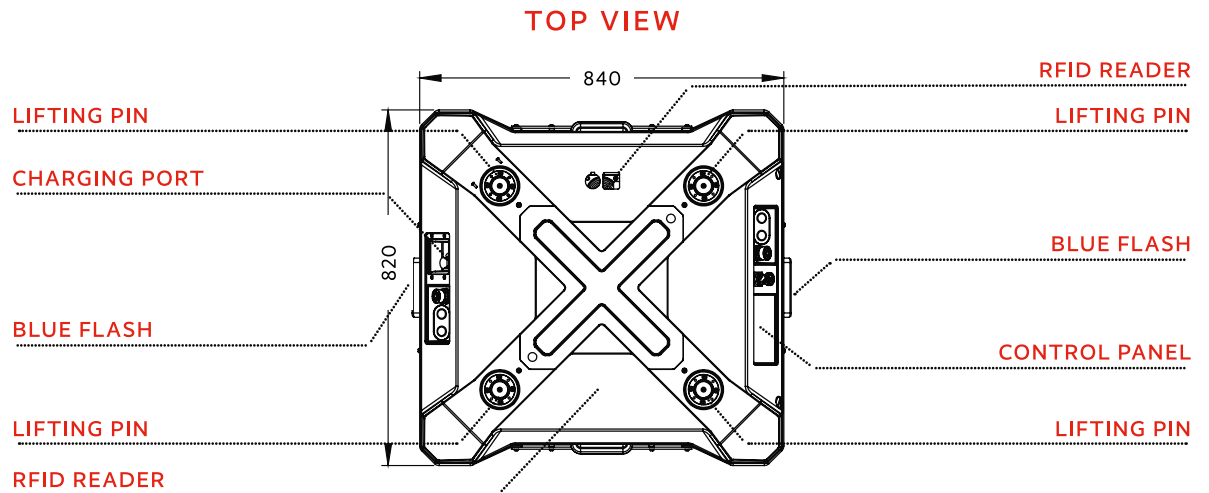
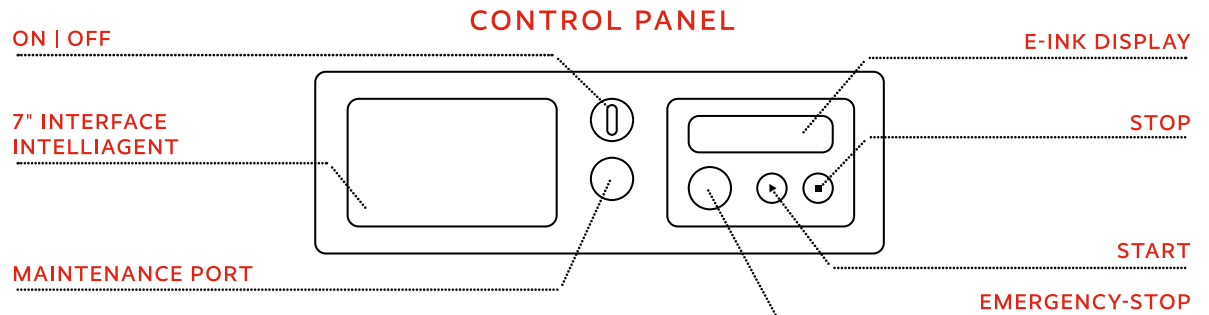
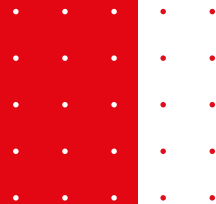

Dimensions in millimeters



 **REDGE**

**WAMECH P.S.A.**

Torowa 3T Street

30-435 Cracow

VAT ID PL6790026622